



## **ADDENDUM NUMBER ONE**

**July 26, 2023**

**IFB#23-912-37  
BALCONY ALTERATIONS FOR GUSTE III "M" BUILDING**

THIS ADDENDUM IS BEING ISSUED TO INCORPORATE THE FOLLOWING IN THE REFERENCED INVITATION FOR BIDS.

**Delete: "06 10 00 ROUGH CARPENTRY" from page i of the Appendix A Table of Contents.**

**Delete: Specification Section 09 91 13 in its entirety.  
Insert: Attached Specification Section 09 91 13 with "(Addendum version)" written in the header of each page.**

**Insert: Attached Drawing 7/A-3 entitled, "Detail: Section at New Extensions of Guards".**

NOTE: To arrange a site visit, email Thelma Bowers [tbowers@hano.org](mailto:tbowers@hano.org).

THIS PORTION INTENTIONALLY LEFT BLANK

**SECTION 09 91 13 – EXTERIOR PAINTING**

**PART 1 - GENERAL**

1.1 RELATED DOCUMENTS

- A. Drawings and general provisions of the Contract, including General and Supplementary Conditions and Division 01 Specification Sections, apply to this Section.

1.2 SUMMARY

- A. This section includes the following:
  - 1. This section includes the following:
    - a) Surface preparation and the application of paint systems on the following exterior substrates:
      - 1) Ferrous metal
      - 2) Wood
- B. Finish painted exterior surfaces as indicate in schedule at the end of this section.

1.3 REFERENCES

- A. ASTM 16D - Definition of Terms Relating to Paint, Varnish, Lacquer, and Related Products.

1.4 DEFINITIONS

- A. Conform to ASTM 16D - Definition of terms relating to Paint, Varnish, Lacquer and Related Products.

1.5 SUBMITTALS

- A. Submit product data on all finish products under provisions of Section 01 33 00.
- B. Submit manufacturer's application instructions under provisions of Section 01 33 00.
- C. Samples for verification:
  - 1. Submit samples on rigid backing 8” square.
  - 2. Step coats on samples to show each coat required for system.
  - 3. Label each coat on sample
  - 4. Label each sample for location and application area.

1.6 DELIVERY, STORAGE, AND HANDLING

- A. Deliver paint materials under provisions of Section 016600 in sealed original labeled containers, bearing manufacturer's name, type of paint, brand name, color designation, and instructions for mixing and/or reducing.
- B. Provide adequate storage facilities. Store paint materials at minimum ambient temperature of 50 degrees F and maximum of 95 degrees F in well ventilated area.
- C. Take precautionary measures to prevent fire hazards and spontaneous combustions.

1.7 ENVIRONMENTAL REQUIREMENTS

- A. Measure moisture content of surfaces using an electronic moisture meter. Do not apply finishes unless moisture contents of surfaces are below the following maximums:
  - 1. Wood: 10 percent.
- B. Ensure surface temperatures or the surrounding air temperature is above 40 degrees F before applying finishes. Minimum application temperatures for latex paints for interior work is between 50 degrees F and 95 degrees F for exterior work. Minimum application temperature for varnish and stain finishes is 65 degrees F.
- C. Provide adequate continuous ventilation and sufficient heating facilities to maintain temperatures above 50 degrees F for 24 hours before, during and 48 hours after application of finishes.
- D. Provide minimum 25 foot candles of lighting on surfaces to be finished.
- E. **THE USE OF SPRAY PAINTING EQUIPMENT AND PAINT ROLLERS FOR THE EXTERIOR WOOD SLEEPERS AND FERROUS METALS SHALL NOT BE PERMITTED. ALL PAINTING SHALL BE DONE BY THE USE OF BRUSHES EXCEPT AS NOTED. CIGAR ROLLERS ARE PERMITTED TO BE USED AT FERROUS METALS.**

1.8 EXTRA MATERIALS

- A. Provide to the Owner not less than one (1) gallon of each color and material used.
- B. Containers shall be tightly sealed and clearly labeled for identification.

**1.9 SURFACES TO BE PAINTED**

- A. Ferrous Metals: All surfaces exposed to view and to the weather.
- B. New wood sleepers: All surfaces exposed to view and to the weather.
- C. Provide painting work at balconies for which painting work is indicated on the *Schedule of Living Units With Balconies* on Sheet G-1 of the Drawings. Paint all ferrous metal railings, balusters, columns, beams, trim, ceiling/roof components. Also, paint all such ferrous metal items on the First Floor and Ground Level wherever such painting work is indicated in the Elevation drawings on Sheet A-2 of the Drawings.

**1.10 SURFACES NOT TO BE PAINTED**

- A. Plastic Fabrications (balcony floor boards).

**PART 2 - PRODUCTS**

**2.1 PAINT, GENERAL**

- A. Painting Schedule: refer to end of Part 3 of this Section for listing of applications for each product.
- B. Products, General: Refer to Part 2 for specific products. Subject to compliance with requirements, provide the products indicated or comparable products from one of the listed manufacturers for each substrate.
- C. Colors: As selected by Architect from manufacturer's full range.
- D. Material Compatibility:
  - 1. Provide materials for use within each paint system that are compatible with one another and substrates indicated, under conditions of service and application as demonstrated by manufacturer, based on testing and field experience.
  - 2. For each coat in a paint system, provide products recommended in writing by manufacturers of topcoat for use in paint system and on substrate indicated.

**2.2 MANUFACTURERS - PRIMER (EXTERIOR)**

- A. Subject to compliance with requirements, provide products produced by one of the following manufacturers:
  - 1. Ferrous Metal:

- a) Sherwin Williams Co. – Kem Kromik® Universal Metal Primer, B50NZ6 Series.
  - b) Devguard-4360 Int-Ext Industrial Primer.
- B. Subject to compliance with requirements, provide products produced by one of the following manufacturers:
- 1. Wood:
    - a) Sherwin-Williams Co. - A-100® Exterior Oil Stain Blocking.
    - b) PPG-Seal Grip Interior Exterior Alkyd Primer 17-941 NF.

### 2.3 MANUFACTURERS - PAINT (EXTERIOR)

- A. Subject to compliance with requirements, provide products produced by one of the following manufacturers:
- 1. Ferrous Metal:
    - a) Sherwin-Williams Co. - Industrial Urethane Alkyd Enamel B54 – 150 Series.
    - b) Devguard – 4308 Industrial Alkyd.
- B. Subject to compliance with requirements, provide products produced by one of the following manufacturers:
- 1. Wood:
    - a) Sherwin-Williams Co. – Super Paint® Exterior Gloss Latex A84 Series.
    - b) PPG-Perma Crete 90-1310 Gloss.

### 2.4 MATERIALS

- A. Coatings: Ready mixed, except field catalyzed coatings. Process pigments to a soft paste consistency, capable of being readily and uniformly dispersed to a homogeneous coating.
- B. Coatings: Good flow and brushing properties; capable of drying or curing free of streaks or sags.
- C. Accessory Materials: Linseed oil, shellac, turpentine, paint thinners and other materials not specifically indicated but required to achieve the finishes specified, of commercial quality.

**PART 3 - EXECUTION**

**3.1 EXAMINATION**

- A. Thoroughly examine surfaces scheduled to be painted prior to commencement of work. Report in writing to the Architect, any condition that may potentially affect proper application. Do not commence until such defects have been corrected.
- B. Correct defects and deficiencies in surfaces which may adversely affect work of this Section.

**3.2 PROTECTION**

- A. Adequately protect other surfaces from paint and damage. Repair damage as a result of inadequate or unsuitable protection.
- B. Furnish sufficient drop cloths, shields, and protective equipment to prevent paint droppings from fouling surfaces not being painted and in particular, surfaces which storage and preparation area.
- C. Place cotton waste, cloths, and material which may constitute a fire hazard in closed metal containers and remove daily from site.

**3.3 PREPARATION**

- A. Comply with manufacturers written instructions and recommendations in "MPI Architectural Painting Specification Manual" applicable to substrates indicated.
- B. Comply with manufacturer's written instructions and recommendations in "MPI Architectural Painting Specification Manual" applicable to substrates and paint systems indicated.
- C. Remove existing sealant where wood or metal surfaces meet masonry surfaces prior to scraping and sanding items to be painted.
- D. Clean substrates of substances that could impair bond of paints, including dirt, oil, grease, and incompatible paints and encapsulates.
- E. Apply paints to produce surface films without cloudiness, spotting, holidays, laps, brush marks, roller tracking, runs sags, ropiness, or other surface imperfections. Cut in sharp lines and color breaks.
- F. Protect work of other trades against damage from paint application. Correct damage to work of other trades by cleaning, repairing, replacing, and refinishing, as approved by Architect, and leave in an undamaged condition.

- G. At completion of construction activities of other trades, touch up and restore damaged or defaced painted surfaces.
- H. Fill holes, checks, and other imperfections in wood surfaces with resin bonding agent and exterior epoxy filler in accordance with the filler manufacturer's instructions. Smooth off and sand smooth to match adjacent surfaces.
- I. Remove grease, rust, scale, dirt, and dust from steel and iron surfaces. Where heavy coatings of scale are evident, removed by wire brushing, grinding, or any other necessary method. Ensure steel surfaces are satisfactory before paint finishing.
- J. Clean unprimed steel surfaces by washing with solvent. Apply a treatment of phosphoric acid solution, ensuring weld joints, bolts and nuts are similarly cleaned. Prime surfaces to indicate defects, if any. Paint after defects have been remedied.
- K. Sand and scrape existing steel surfaces to remove all existing paint and rust. Clean surfaces with solvent. Prime bare steel surfaces.

#### 3.4 APPLICATIONS

- A. Apply each coat at proper consistency.
- B. Each coat of paint is to be slightly darker than preceding coat unless otherwise approved by the Architect.
- C. Sand lightly between coats to achieve required finish.
- D. Do not apply finishes on surfaces that are not sufficiently dry.
- E. Allow each coat of finish to dry before following coat is applied, unless directed otherwise by manufacturer.

#### 3.5 CLEANING

- A. As work proceeds and upon completion, promptly remove paint where spilled, splashed, or spattered.
- B. During progress of work, keep premises free from any unnecessary accumulation of tools, equipment, surplus materials, and debris.
- C. Upon completion of work, leave premises neat and clean, to the satisfaction of Architect.

**HOUSING AUTHORITY OF NEW ORLEANS  
BALCONY ALTERATIONS AT THE  
GUSTE III HOUSING COMMUNITY, BUILDING M**

**December 12, 2022  
Architect's Proj. #22-013  
(Addendum version)**

**3.6 PAINTING AND FINISHING SCHEDULE (EXTERIOR)**

**A. Ferrous Metal:**

1. Paint Finish - 1 coat alkyd primer.
2. Paint Finish - 2 coats alkyd gloss finish.

**B. Wood:**

1. Paint Finish - 1 coat alkyd exterior primer.
2. Paint Finish - 2 coats acrylic latex finish, sheen as selected by Architect.

**END OF SECTION 09 91 13**



# DRAWING

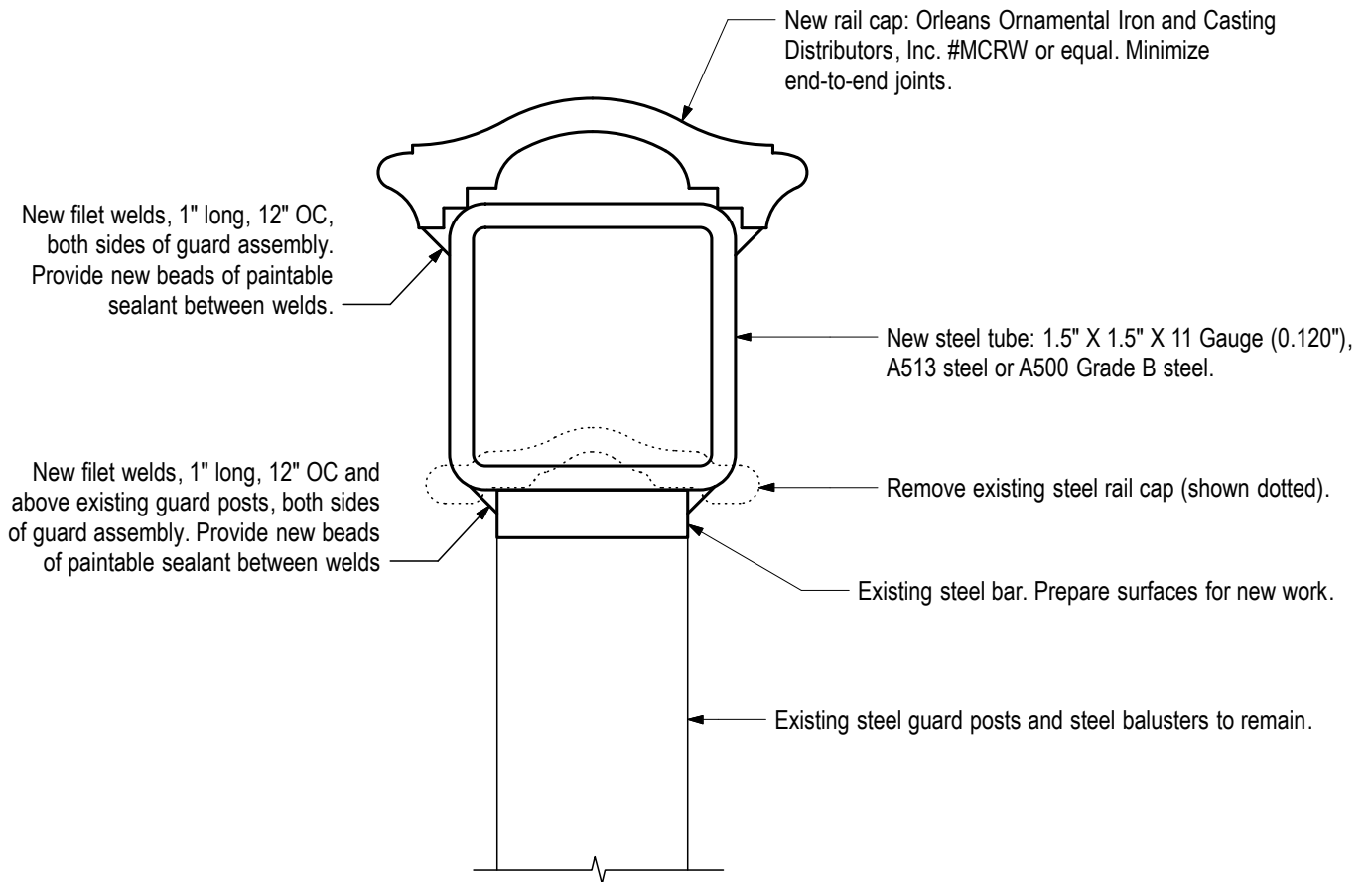

## Notes:

1. Provide a guard extension as shown in this Detail at all Type 1, 2, 3, 4, 5, 6, and 7 balconies, all along the tops of all the existing guard assemblies.
2. Some balconies have curved guard assemblies; see Drawing 5/A-1. At these balconies, the new guard extensions shall be curved to match the curvature of the existing guard assemblies.
3. At balconies with round columns, fit new components tight to column shafts; provide rounded cuts as required.
4. Paint new and existing components of guard assemblies.

7  
A-3

## Detail: Section at New Extensions of Guards

Scale: Actual Size

**Quotes must be received by the Housing Authority of New Orleans (HANO) in the Office of Procurement and Contracts by 2:00 p.m., local time on Wednesday, August 9, 2023. All terms and conditions shall remain as stated in the original Request for Quotes. All addenda must be acknowledged.**

**END OF ADDENDUM NUMBER ONE**